

# High-Speed Digital Molding

A disruptive alternative to traditional injection molding for low-volume plastic part production

Digital molding is a massively scalable additive manufacturing process that speeds and simplifies the production of plastic parts.

3D Systems' digital molding technology enables designs to go straight from CAD to manufacturing without tooling, facilitates on-the-fly iterations of part designs, accelerates production transitions to new designs without retooling, and rapidly manufactures parts that are too complex for traditional injection molding.

This paper outlines the evolution of digital molding, explains how it works, details benefits for manufacturers, reveals business drivers for the technology, and provides perspectives from an industry expert. Cost and time savings claims are documented by benchmarks that demonstrate the performance of digital molding versus traditional injection molding.

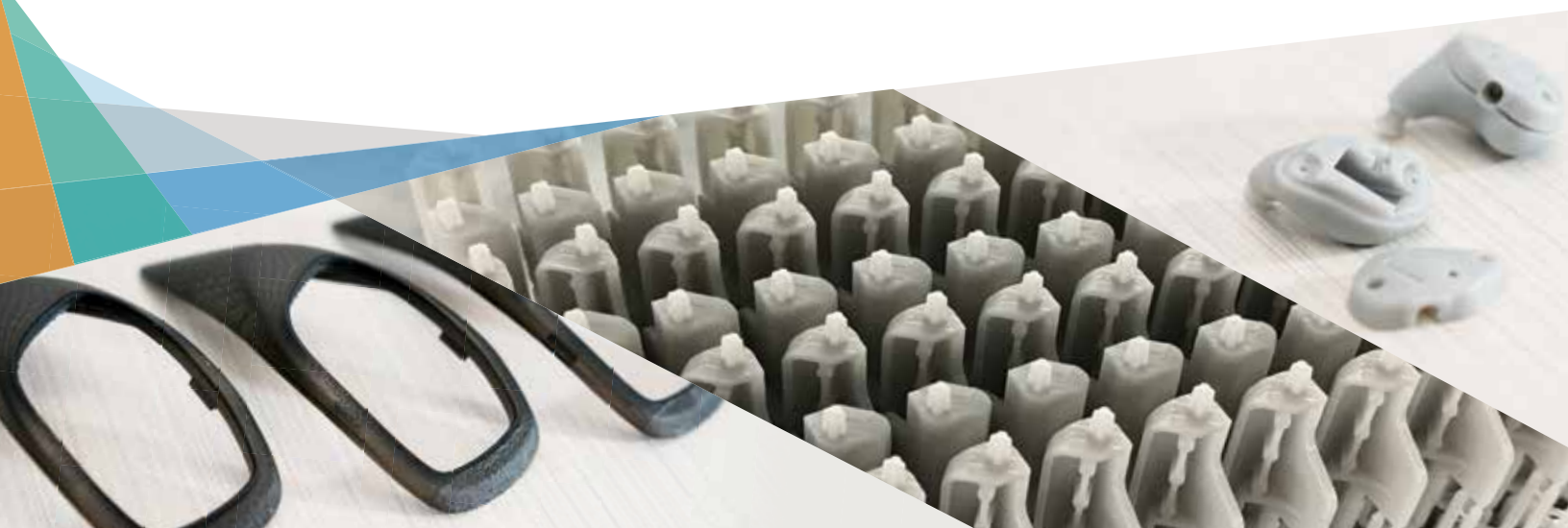

## Introduction

- A radical departure after nearly 150 years of tooling
- The massively scalable, modular approach to high-speed plastic part production
- New materials enabled by less time in the vat
- The technological confluence that makes digital molding possible

### Disruptive Change After Nearly 150 Years

Since its invention nearly 150 years ago, injection molding has been a linchpin of the manufacturing world.

The process has improved measurably over the years with the inventions of soluble forms of cellulose acetate, screw injection machines, the gas-assisted injection molding process, and the extensive range of material options.

Injection molding manufacturing has progressed from simple objects such as buttons and combs to complex products for practically every industry, including automotive, aerospace, healthcare, consumer products, construction, packaging and many more.

But, one thing about injection molding has not changed: the need for tooling. Although it has been simplified and sped up by advances in CNC and 3D printing, the tooling of increasingly complex injection molds is still measured in weeks and sometimes months.

### A Massively Modular Approach

The 3D Systems approach to tool-less digital molding is being made possible by a modular manufacturing process called Figure 4™, a 30-year-old stereolithography (SLA) configuration patented by 3D Systems' co-founder Chuck Hull.

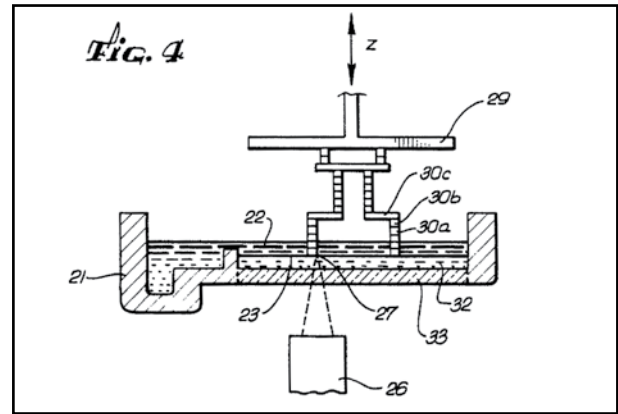

*Figure 4™ delivers ultra-fast additive manufacturing technology in discrete modules, allowing it to be placed into automated assembly lines and integrated with secondary processes, including washing, drying and curing.*

Using arrays of manufacturing modules serviced by robotics, a finished geometry can be output with astonishing speed, and throughput can be optimized with downstream workflows. Specific cycle times and costs will vary based on the specific part or geometry printed. For example, the automotive vent cited in this paper demonstrated a cycle time equivalent of 95 seconds.

### The Advent Of New Materials

The processing speed of Figure 4 technology enables use of reactive plastic resins with short vat lives, leading to tough, functional parts such as those used in thermoplastic applications.

Unlike other photopolymer 3D printing, Figure 4 is capable of manufacturing parts in hybrid materials (multi-mode polymerization) that offer toughness, durability, biocompatibility, high temperature deflection, and even elastomeric properties. This opens the door to new end-use applications in the fields of durable goods, automotive, aerospace, healthcare and beyond.

### Technology That Makes It Possible

Thirty years ago, Chuck Hull had a vision of how Figure 4 could lead to extremely fast production of SLA parts. The exceptional speed of the process would drastically shorten the time of liquid material in the vat, enabling a wide range of hybrid materials that mirror those used in traditional molding processes. The problem was the related technological advancements required to turn his vision into reality were not available—until now.

Progress in several areas now makes digital molding possible:

- Continuous advancement of SLA technology, making it faster, simpler to use, and able to produce parts with much greater dimensional accuracy.
- Ongoing development of materials, including multi-material mixes that rival the physical properties of traditional injection molded parts.
- Much greater speed in processing raw materials in the vat, leading to better, more diverse material properties.
- Digital texturing that enables complex, aesthetically pleasing parts within a single run without extra design and processing time.
- Development of CAD/CAM software that enables design for the unique capabilities of 3D printing, including organic and complex designs, consolidation of parts within an assembly, and use of lighter-weight materials with greater strength.
- Advanced robotics systems that enable fast connections between modular operations and a high level of scalability.

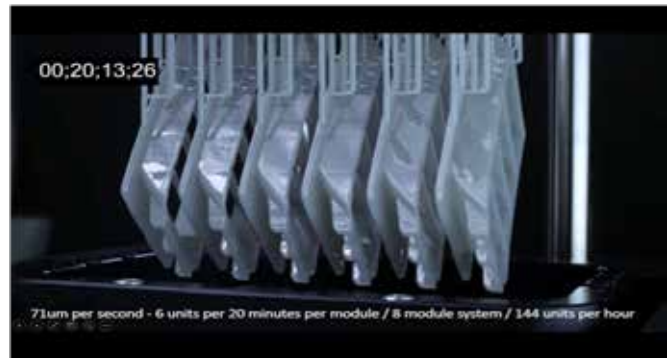

Over the past several years, 3D printing has provided an attractive complement to traditional injection molding. For some manufacturers, it has enabled direct manufacturing of parts that would have traditionally required injection mold tooling. For others, 3D printing has delivered fast production of plastic or metal molds that feature conformal cooling and other features for greater efficiency and temperature control. Digital molding is the next innovation.

Much like digital photography, digital printing and digital video, digital molding has come about through a confluence of complementary technologies that have been intelligently choreographed for speed, accuracy and efficiency.

### How Digital Molding Works

- Automated stages reduce the need for human intervention
- Membrane micro-DLP arrays connected by robotic arms
- Architected to leverage Industry 4.0 practices and standards
- Massively scalable and can operate within automated production lines

**Digital molding has come about through a confluence of complementary technologies that have been intelligently choreographed for speed, accuracy and efficiency. Robotic arms take the parts through each step of the primary and secondary processes, allowing streaming production of parts.**

The digital molding process invented by 3D Systems is comprised of discrete modules for every step required in direct 3D production. Each stage is automated, reducing the need for human intervention. Following input of the digital benchmarking vent file, the first part was produced within 92 minutes, followed by additional vents at rates equivalent to one recurring unit every 95 seconds.

The Figure 4 technology that drives digital molding comprises an array of super-fast membrane micro-DLP (Digital Light Processing) printers. The array enables the digital molding process to take advantage of parallel processing efficiencies. Printers within the array are called “engines,” and each one is extremely fast at producing physical objects. So fast, in fact, that 3D Systems characterizes the process as a motion or velocity. Depending on the geometry and material, a 3D object can be pulled from a 2D plane at speeds measured in millimeters per minute.

Robotic arms take the parts through each step of the primary and secondary processes, allowing streaming production of parts. The robotic arms pull the parts swiftly from the resin vat and take them through the washing, drying and curing operations. Digital inspection can also be integrated into Figure 4 modules, enabling the sensors and data capture required to leverage Industry 4.0 practices and strategy.

In combination with 3D Systems’ software, Figure 4 modules can communicate in real time using industry standard

protocols such as MTConnect and OPC Unified Architecture (OPC UA). 3D Systems’ software is designed to provide operating and support intelligence both locally on the factory floor and remotely via web and cloud connectivity, promoting efficient data exchange for smart manufacturing.

Digital molding as implemented by 3D Systems is massively scalable and can operate within automated production lines. It can handle long- and short-run batches and allows fast switching of production to different parts. This gives manufacturers the ability to quickly iterate a design and immediately manufacture an end-use part.

## Benefits

**Freeing the production process from the need for tooling means faster production time, greater flexibility and the ability to create multiple products simultaneously.**

Specific benefits within the production process include:

- **No wait time for tooling:** Once the 3D part design is completed, production can begin immediately. With traditional injection molding, it typically takes weeks to complete the design and manufacturing of tooling.
- **No minimum order quantity:** Paired with the full design flexibility of a digital workflow, the ability to produce parts without tooling makes it possible to deliver parts in any quantity without economic penalty.
- **Lower costs:** Digital molding reduces labor, machining, iteration and testing costs.



- **High-quality, durable materials:** Materials rival quality requirements for specific applications. Hybrid material formulations demonstrate a wide range of physical properties similar to what is addressed by various thermoplastics used in injection molding.
- **No batching:** Live streaming production of parts eliminates massive batches of parts within the production process.
- **Scalable with production needs:** Systems can be easily scaled by simply adding modules.
- **No wait time to change tooling:** Manufacturers can quickly switch part geometries for immediate production.
- **Fast production of a variety of part geometries:** Multiple part geometries can be produced in each build, or short run parts can be configured as batches, allowing flexible production of multiple part types.
- **Greater part complexity:** 3D printers can produce parts with complex shapes and optimized features that would be impossible to create with traditional injection molding.
- **More efficient part customization:** Part designs can be customized and then manufactured immediately without the constraint of tooling.
- **Eliminating physical storage issues:** Digital molding removes storage-related issues such as logistics management, warehousing, degradation of parts and molds, lost inventory, and time to locate and fetch parts.
- **Complements existing production methods:** Digital molding configurations can be integrated into other shop floor processes and used for Low Rate Initial Production (LRIP) before switching to mass production with traditional injection molding.



*Figure 4™ Production packages the design flexibility of additive manufacturing in configurable, in-line production modules to deliver a customizable and automated direct 3D production solution.*

## Business Drivers

- Effect on time to market for low-volume parts
- Potential for lowering design, production and labor costs
- Streamlining of product lifecycle management (PLM)
- Implications for greater part complexity and faster optimization/customization

### No Tooling Yields Faster Time To Market

Tooling for injection molding takes time—not only to manufacture, but it takes time to design, make changes so the design will be moldable, and finally cut a molding tool from metal. Once the tool is cut, it can only be changed by repeating the same process and hoping for better results. It is a fixed chunk of metal, time and cost.

The advantage of digital molding is that it gets rid of tooling. Design for digital molding needs to address functionality only, not draft angles, undercuts, side inserts and other features required for injection molding. As compared to the several weeks it takes for the initial design of a textured injection molded part, digital molding can be done in a matter of hours, as demonstrated by the automotive vent used in the benchmark tests cited in this paper.

Digital molding eliminates CNC machining, which can take two or three weeks, as well as the day of initial shots typically required to set temperature, dwell time and other parameters.

Within 11 days, a digital molding array with eight modules can turn out 10,000 units of a textured automotive vent, according to 3D Systems' benchmark tests, while the injection molding process was still in the design stage. By the time 10,000 units of the automotive vent could be produced using traditional injection molding, a manufacturer using digital molding could have produced nearly 14,000 units.

The CAD-to-production speed of digital molding makes it a perfect candidate for LRIP (Low Rate Initial Production) or bridge manufacturing, enabling companies to go to market much faster, with the option to convert to injection molding to ramp up volume when tooling is ready.

### **The Cost Factor**

Tooling is, of course, still necessary if you need several hundreds of thousands or millions of parts. A \$30,000 tool divided by a million parts is \$0.03 cents a unit for the tooling cost. That is a great value.

The value equation breaks down, however, when there is a low volume of parts, from one to approximately 1,000 parts. In that case, the cost of each injection molded part can be 10 to 100 times as much as it would be using digital molding.

Besides the cost of actual production of a traditional injection molding part, there are other financial factors to consider, such as a highly paid labor force during a tooling design period that typically lasts weeks versus the hours needed to design a functional part for digital molding.

With a tool-less process, manufacturing comes immediately after design. Manufacturers do not have to factor in the additional labor, materials and CNC machining and testing costs before manufacturing begins in earnest.

Digital Molding also reduces the cost of design iterations—if the product does not look or work as anticipated, it is changed within CAD software and ready for direct manufacturing—no new tooling to design, no mold production or physical testing required.

### **Product Lifecycle Management (PLM) Implications**

The initial benefit of digital molding within PLM is obvious: the ability to begin shipping products almost immediately after final design. Anything that speeds time to market delivers a definitive competitive advantage and digital molding is among the greatest enablers in decades for achieving that goal.

The flexibility to make fast design changes, to iterate product designs for better performance, and to provide timely updates will certainly prove to be a major benefit to manufacturers' bottom lines.

As products begin to reach the later stages of their lifecycle, digital molding continues to deliver major value. Take the case of manufacturers that have discontinued a product. Manufacturers of certain products are legally required to have replacement parts available for many years after the products have been discontinued.

These replacement parts are often needed only in small quantities. If part replacements are not in inventory, the manufacturer needs to find the mold, make sure it is functional, install it in the injection molding machine, conduct test shots, and then produce a small run of parts at considerable time and expense.

If the mold is damaged, worn out or rusted, then the costs can multiply to the tens of thousands of dollars to recreate the tooling to manufacture what might be only a handful of parts. Delivery could take weeks compared to days for a digitally stored part.

Digital molding enables replacement parts to be produced on demand. The only storage expense is for digital file space and the parts can be manufactured immediately from the existing CAD file. It is the ideal solution for low-volume, on demand, tool-free part production.

### **Faster, Cheaper, Better Parts**

One of the major benefits of 3D printing—the ability to manufacture complex parts at no additional cost—is amplified when compared to the time and costs for adding features such as textures to traditional injection molding parts.

Manufacturing an automotive vent with textures such as the part used in this paper's benchmark tests increases the design and production time for injection molding.

But with 3D printing, complexity has no effect on time or cost. In fact, in many instances it can actually decrease costs by using less or lower-weight material while maintaining the same or better strength and durability.

Since it is not based on analog technology, digital molding geometries can be adjusted practically on the fly. There is no physical tooling to change: modify the digital file and start manufacturing immediately.

In the case of the automotive vent, the surface textures were changed on the fly from a buffalo-hide leather to a carbon-fiber effect in real time. With digital molding, parts can be adjusted in minutes to meet a customer's or specific market's preference. With injection molding, this requires retooling.

## **Benchmark Methodology and Results**

### **The Methodology**

3D Systems conducted a benchmarking study comparing design and production of an automotive vent using digital molding with traditional injection molding production.

The benchmark was overseen by engineers with nearly 50 years of combined experience in digital and traditional design and manufacturing methods. Design and production were done by companies with expertise in CAD/CAM, CNC machining, injection molding design and additive manufacturing.

### **Time Measurement**

Time measurement for digital molding was based on actual time required to design the textured automotive vent for 3D printing. Engineers then measured the time it took to stream the 3D design data through a configuration containing eight engines.

Time measurement for injection molding design started once design data was submitted to the low-volume injection molding supplier. The supplier conducted a design-for-manufacturing analysis, then returned the file to 3D Systems' engineers for modifications and final iterations. The supplier then provided 3D Systems with a tooling progress report that tracked the time for mold layout, mold design and each of the steps to create the tooling and produce the parts.

### Tooling And Part Costs

Tooling quotes were received from three different injection molding suppliers. Two were low-volume, rapid-injection molding services and the other was a traditional high-volume supplier. Tooling quotes ranged from \$7,565 to \$9,700.

Part quotes were received from the same three suppliers and ranged from \$0.98 to \$2.52 depending on volumes and the manufacturer.

The Figure 4 comparison was made against the internal tooling and part costs of one of the rapid-injection molding suppliers.

### Benchmark Results

Comparisons between digital molding based on 3D Systems Figure 4 technology and traditional injection molding show major time and cost differences in design, development and tooling processes.

CAPABILITY	FIG 4. (STREAMING)	INJECTION MOLDING
Design Time	3 hours	2 days
Tooling Design	0 hours	3 days
Tooling Time	0 hours	14 days
Estimated CAD, Tooling Design & Tooling Labor	\$121	\$4,315*
Internal Tooling Cost	\$0	\$4,850
Time to First Part	92 minutes	15 days
Seconds per Part**	95 sec/U	55 sec/U
Total Cost per Part (@500)***	\$7.90	\$10.50
Cost per Part (@10,000)***	\$7.90	\$1.29
Design Adjustable	Yes	No

\* Based on eight-hour days and U.S. Bureau of Labor Statistics figures of \$40.19 per hour for mechanical engineers and \$24.17 per hour for tool and die makers.

\*\* Based on an eight-engine automated printing system.

\*\*\* Total cost accounts for tooling amortization plus material cost per part.

## Figure 4 Direct 3D Production vs. Injection Molding

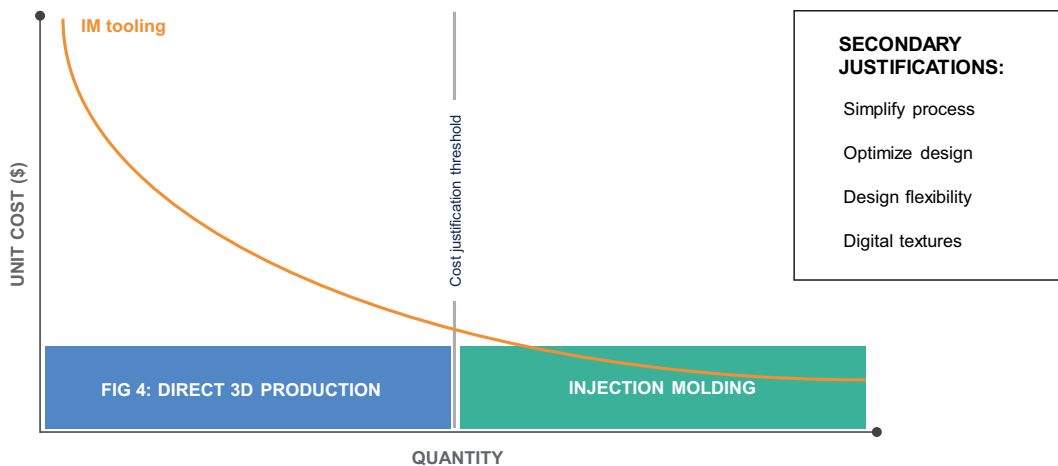





Initial cost of tooling for traditional injection molding created in-house was \$4,850 versus no tooling costs for digital molding based on 3D Systems Figure 4 technology. The volume justification for choosing digital molding over conventional injection molding in this case is up to 700 units.

## Perspective From An Industry Expert

Tim Shinbara is vice president of the Association for Manufacturing Technology (AMT). He supports AMT members by increasing global technology awareness, improving access to tech-related resources and expertise, and promoting engagement within the manufacturing technology space.

He has studied and documented the progress of additive manufacturing and has thoughts about the potential impact of digital molding on manufacturing. Comments from a recent interview with Shinbara are excerpted below.

### The Potential For Digital Molding

*"Being able to move continuously (and autonomously) among manufacturing steps greatly reduces step-wise functions that may introduce unacceptable variances. It is highly desirable to mitigate delays and disruptions in production that accompany part removal, material recovery and equipment recovery (think hitting "reset" to begin making*

*another batch of parts on that same machine).*

*"Advancing the state of SLA to serve higher performance end-use requirements by incorporating automated assembly processes coupled with part-material mixtures that can compete with injection molding provides a logical next step for industrial additive manufacturing."*

### Changing The Landscape For Low-Volume Direct Manufacturing

*"It certainly changes the landscape for the types of parts that require only slight changes to geometries, but changes that are significant enough that the manufacturer would need to modify molds and patterns."*

*"Even if the demand for such parts ultimately makes business sense for injection molding, being able to get low-rate production out to customers sooner may provide enough value-proposition to even endure slightly higher costs to customers. There would then be a transfer to full injection molding production, leaving manufacturers room to amortize the additive manufacturing approach into a single piece-price or offer the lower price once they've transitioned to injection molding processes."*

### Producing A New Class Of Hybrid Materials

*"The use of hybrid materials provides a range of end-use properties that are highly desirable to folks wanting the geometric freedom of additive manufacturing along with the literal flexibility of things like living hinges and morphed structures with varying mechanical properties—all from the same build."*

*"It certainly changes the landscape for the types of parts that require only slight changes to geometries, but changes that are significant enough that the manufacturer would need to modify molds and patterns."*

### **The Implications of On Demand Delivery for Low-Volume Customized and/or Replacement Parts within Product Lifecycle Management**

*"Such capabilities would enable a manufacturing firm to further support longer-term maintenance or resurrected parts/ assemblies. Knowing that such capabilities exist could also have an impact on the design for manufacturing, overall lifecycle costs and structuring (and servicing) of warranties, and contractual obligations. It ultimately could have high potential to reduce the overall cost of the part for production, maintenance and refurbishment, reworking and reordering."*

### **Enabling On Demand Manufacturing of Optimized Parts with Complex Shapes and Textures**

*"By incorporating the preferred surface finishes achieved by SLA along with the cost-effectiveness of injection molding there is a high potential to disrupt the low- to medium-volume space of parts typically allocated to injection molding. This better enables on-demand capabilities that may have an attractive value-proposition."*

*"This technology could be applicable to on-demand scenarios such as enabling last-minute design changes with no significant increases in cost or no delays; offering a wide range of products (geometries, materials, functionality) that are producible by the on-demand manufacturer; and lowering overhead (for storage and capital expenditures) to provide maximum flexibility in pricing, production and servicing business structures."*

### **Conclusion**

**Digital molding**, as implemented in high-speed, modular and massively scalable configurations by 3D Systems, **has the immediate potential to be a disruptive alternative to traditional injection molding for low volume plastic part production.**

The 3D Systems approach offers benefits that span the complete design, engineering, production and maintenance phases of product lifecycle management. Business drivers for digital molding include faster time to market, cost savings, greater product development and maintenance productivity, and the ability to design, produce and optimize plastic parts faster, cheaper and better than ever before.

### **Explore Digital Molding for Your Business**

- [Discover the design benefits of additive manufacturing](#)
- [Contact a 3D Systems specialist](#)
- [Learn more about 3D Systems Figure 4 solutions](#)

