

DuraForm® PA Plastic

Durable polyamide (nylon) material for real-world physical testing and functional use.

General Properties

MEASUREMENT	CONDITION	METRIC	U.S.
Specific Gravity	ASTM D792	1.00 g/cm ³	1.00 g/cm ³
Moisture Absorption - 24 hours	ASTM D570	0.07%	0.07%

Mechanical Properties

MEASUREMENT	CONDITION	METRIC	U.S.
Tensile Strength Ultimate (MPa/PSI)	ASTM D 638	43	6237
Tensile Modulus (MPa/KSI)	ASTM D 638	1586	230
Elongation at Break (%)	ASTM D 638	14	14
Flexural Strength, Ultimate (MPa/PSI)	ASTM D 790	48	6962
Flexural Modulus (MPa/KSI)	ASTM D 790	1387	201
Hardness, Shore D	ASTM D2240	73	73
Impact Strength (notched Izod, 23°C)	ASTM D256	32 J/m	0.6 ft-lb/in
Impact Strength (unnotched Izod, 23°C)	ASTM D256	336 J/m	6.3 ft-lb/in
Gardner Impact	ASTM D5420	2.7 J	2.0 ft-lb

Data was generated by building parts under typical default parameters. DuraForm® PA Plastic was processed on a base-level HiQ™ SLS System at 13 watts laser power, 5 m/sec [200 inches/sec] scan speed, and a powder layer thickness of 0.1 mm [0.004 inches].

Features

- Excellent surface resolution and feature detail
- Easy-to-process
- Compliant with USP Class-VI testing
- Compatible with autoclave sterilization
- Good chemical resistance and low moisture absorption

Benefits

- Nicely balanced mechanical properties and processability
- Build prototypes that withstand functional testing
- Produce durable end-use parts without tooling
- Create accurate and repeatable parts as demanded by manufacturers
- Machinable and paintable for demonstration parts

Applications

- Complex, thin-wall ductwork
- Functional prototypes that approach end-use performance properties
- Appropriate for low- to mid-volume rapid manufacturing
- Medical applications requiring USP Class-VI compliance, or biocompatibility
 - Motorsports
 - Aerospace
- Housing and enclosures
- Impellers and connectors
- Consumer sporting goods
- Vehicle dashboards and grilles
- Snap-fit designs
- Parts requiring machining or joining with adhesives

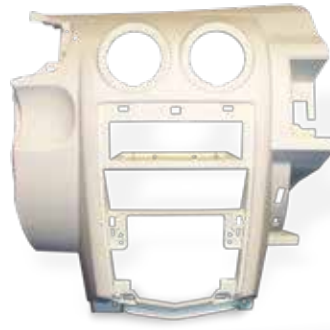

DuraForm® PA Plastic

For use with all selective laser sintering (SLS) systems

Thermal Properties

MEASUREMENT	CONDITION	METRIC	U.S.
Heat Deflection Temperature	ASTM D 648 @ 0.45 MPa @ 1.82 MPa	180 °C 95 °C	356 °F 203 °F
Coefficient of Thermal Expansion ($\mu\text{m}/\text{m}\cdot^{\circ}\text{C}$ / $\mu\text{m}/\text{in}\cdot^{\circ}\text{F}$)	ASTM E 831 0-50 °C 85-145 °C	82.6 179.2	45.9 99.6
Specific Heat Capacity	ASTM E1269	1.64 J/g·°C	0.392 BTU/lb·°F
Thermal Conductivity	ASTM E1225	0.70 W/m·K	4.86 BTU-in/hr-ft ² ·°F
Flammability	UL 94	HB	HB

Electrical Properties

MEASUREMENT	CONDITION	METRIC	U.S.
Volume Resistivity	ASTM D257	5.9×10^{13} ohm-cm	5.9×10^{13} ohm-cm
Surface Resistivity	ASTM D257	7.0×10^{12} ohm	7.0×10^{12} ohm
Dissipation Factor, 1 KHz	ASTM D150	0.044	0.044
Dielectric Constant, 1 KHz	ASTM D150	2.73	2.73
Dielectric Strength	ASTM D149	17.3 kV/mm	439 kV/in

Data was generated by building parts under typical default parameters. DuraForm® EX Plastic was processed on a base-level HiQ™ SLS System at 13 watts laser power, 5 m/sec [200 inches/sec] scan speed, and a powder layer thickness of 0.1 mm [0.004 inches].



middle east
3D PRINTING THE FUTURE

3D SYSTEMS®
DISTRIBUTOR | Middle East & North Africa

U.A.E Office : 3204, Prism Tower, Business Bay, P.O. Box 28820, Dubai, U.A.E.

K.S.A Office : Al Saif Tower, 6th Floor, King Abdullah Street, Near Intersection with Olaya Street, Riyadh, K.S.A.

Tel : +971.4.443.3853 ; Fax : +971.4.443.3938 ; Email : info@3d-me.com ; Website: www.3d-me.com